

MODEL **KR-500**
INSTRUCTION MANUAL
ELEVATION ROTOR

FOR : OSCAR MOONBOUNCE AND SATELLITE TRACKING

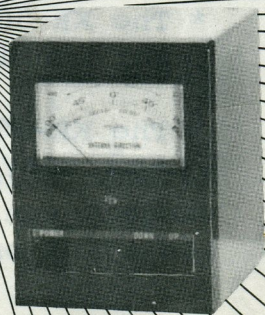
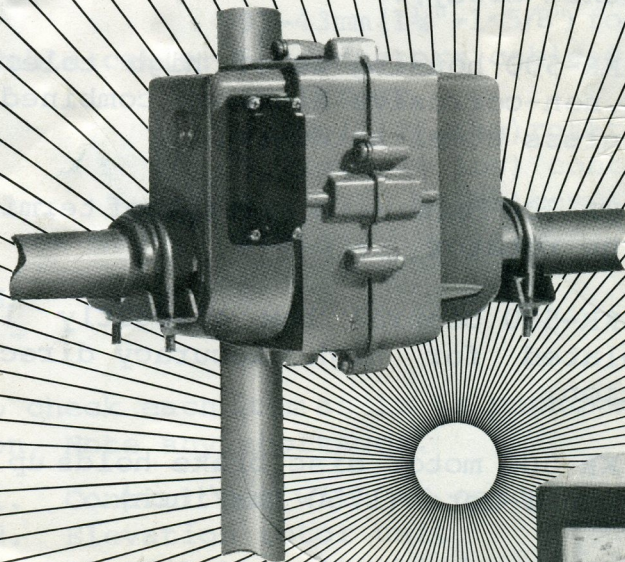

OUTSTANDING FEATURES:

- * The KR-500 is an elevation rotator specifically designed for 180 degree vertical rotation of communication antennas.
- * The KR-500 utilizes heavy duty construction throughout for use with more than one antenna (stacked array).
- * The KR-500 housing is of high tolerance die-cast, non-corrosive aluminum combined with all stainless steel hardware.
- * The KR-500 features a waterproof terminal block on the rotator.
- * The KR-500 control box circuitly is voltage regulated for high accuracy direction indication.
- * The KR-500 motor disc brake holds up to 2000Kg per centi-meter (1750 lbs/inch).
- * The KR-500 has been designed for low maintenance and easy repair.

SPECIFICATIONS:

Power requirement: AC 117/220 volts 50/60Hz.
Power consumption: 30VA.
Motor voltage: 24 volts AC.
Rotation time: 74 sec at 50Hz/180 degree.
61 sec at 60Hz/180 degree.
Stopper: 180 degree mechanical pin stopper.
Rotation torque: 400Kg/centi-meter, (350 lbs per inch, (motor disc type).
Brake: 2000Kg/centi-meter, (1750-lbs per inch).
Accuracy: ± 3 per cent.
Mounting: 38-63mm ($1\frac{1}{2}$ "- $2\frac{1}{2}$ ") for mast.
32-43mm ($1\frac{1}{4}$ "- $1\frac{5}{8}$ ") for boom.
Recommendable cable: 6 conductors cable, #22 AWG or larger.
Weight: 3.3Kg (7.26 lbs) rotor unit.
1.7Kg (3.74 lbs) controller
5.5Kg (12.1 lbs) complete in carton.

UNPACKING:

Be sure to check each item as it is unpacked from the carton, Note any shortages.

1. Control box with AC cord.
2. Elevation rotor unit.
3. Plastic bag with hardware.

Inspect all items to insure no shipping damages has occurred, In case of damage or shortage report the problem to the dealer where the unit was purchased for repair or replacement.

PROBLEM OF BINDING

See Figure # 1 showing the position of the mast clamps. Make sure all four (4) mast mounting studs (a side of screw in short) are fully threaded into the housing.

See Figure # 2 for the installation and adjustment of the boom clamps.

Check the control box reading after the power cable is hooked up. The reading should be 90° when array points vertical. (matching meter and array) The reading can be adjusted slightly with potentiometer on the rear of the control unit. The rotor is adjusted at the factory to the "90°" position.

Fig-1

NO	QTY	DESCRIPTION
1	8	8φ SPRING WASHER
2	8	8φ NUT
3	8	8φ WASHER
4	4	8φ STUD BOLT
5	6	BOOM/MAST CLAMP
6	2	U BOLT
7	4	6φ WASHER
8	4	6φ SPRING WASHER
9	4	6φ NUT

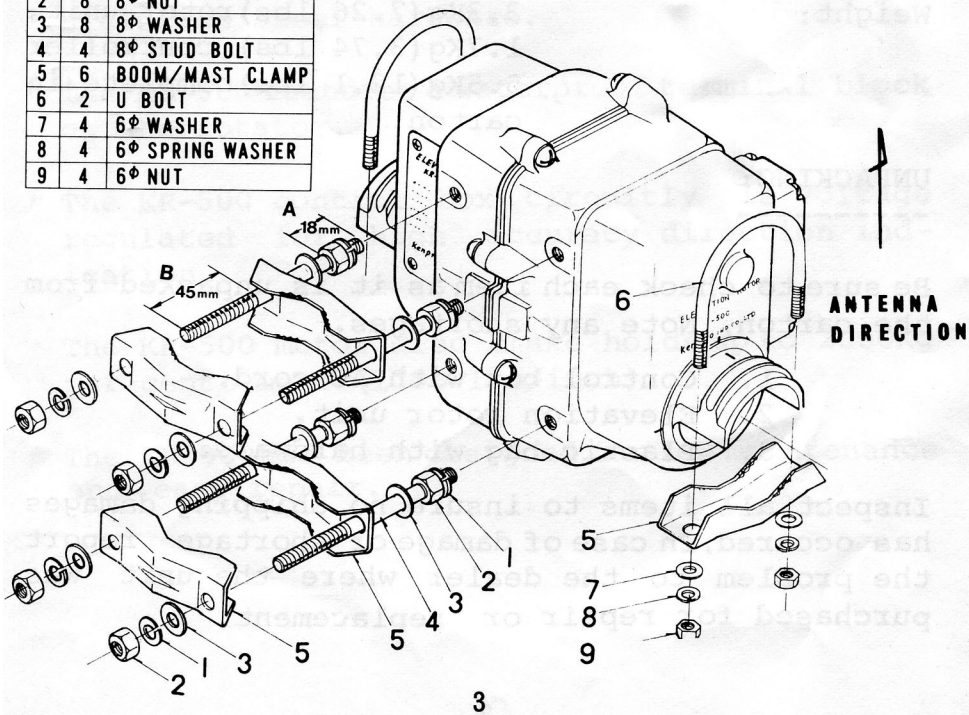
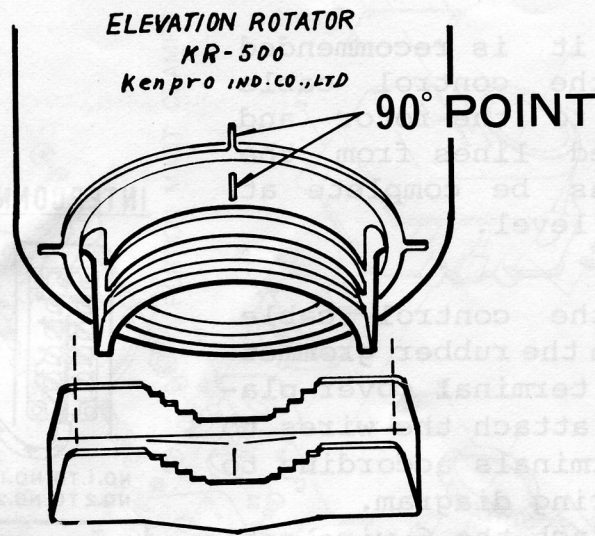

Fig-2

CHECK POSITION



MOUNTING TO THE MAST:

The KR-500 can be mounted to a short section of mast prior to installation on a tower. The main support boom may also be installed through the rotor.

It is recommended that the boom be equal weight on either side of the rotor. When installing the antennas on the boom, be sure the weight is evenly distributed in front and rear of the rotor for proper balance. If front mounting of the antennas is desired, counter balance weights should be added behind the boom to equalize the weight distribution.

To check for proper antenna position, rotate the array through the entire 180 degree range. It is recommended that entire installation be assembled and tested at ground level whenever possible.

INTERCONNECTION/WIRING:

Again it is recommended that the control cable wiring to the rotor and the feed lines from the antennas be complete at ground level.

Feed the control cable through the rubber grommet in the terminal cover plate and attach the wires to the terminals according to the wiring diagram.

Now attach the 6 wire cable to the control unit #1 to #1, #2 to #2 etc, to #6, next replace the terminal cover plate.

Adequate slack for both the elevation rotor (KR-500) cable and the feed lines should be allowed around the Azimuth horizontal rotator for 360-degree rotation.

Feed lines should be taped to the boom on either side of the rotor and enough slack left to allow complete 180 degree rotation with no cable stress.

INTERCONNECTION

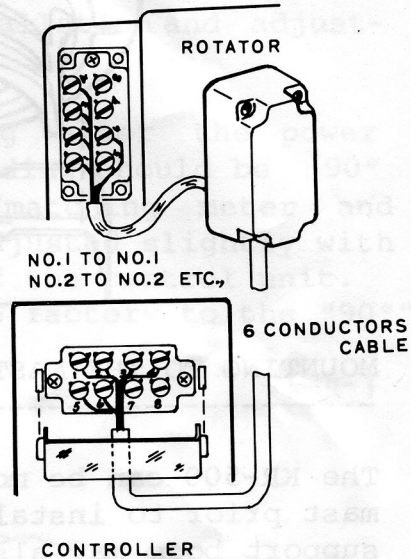

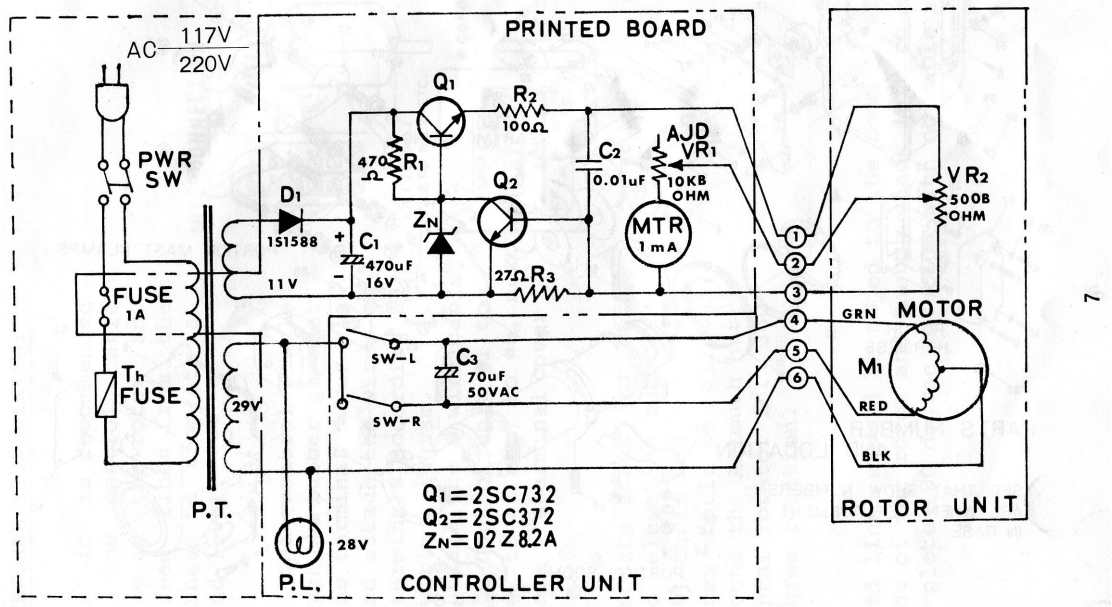
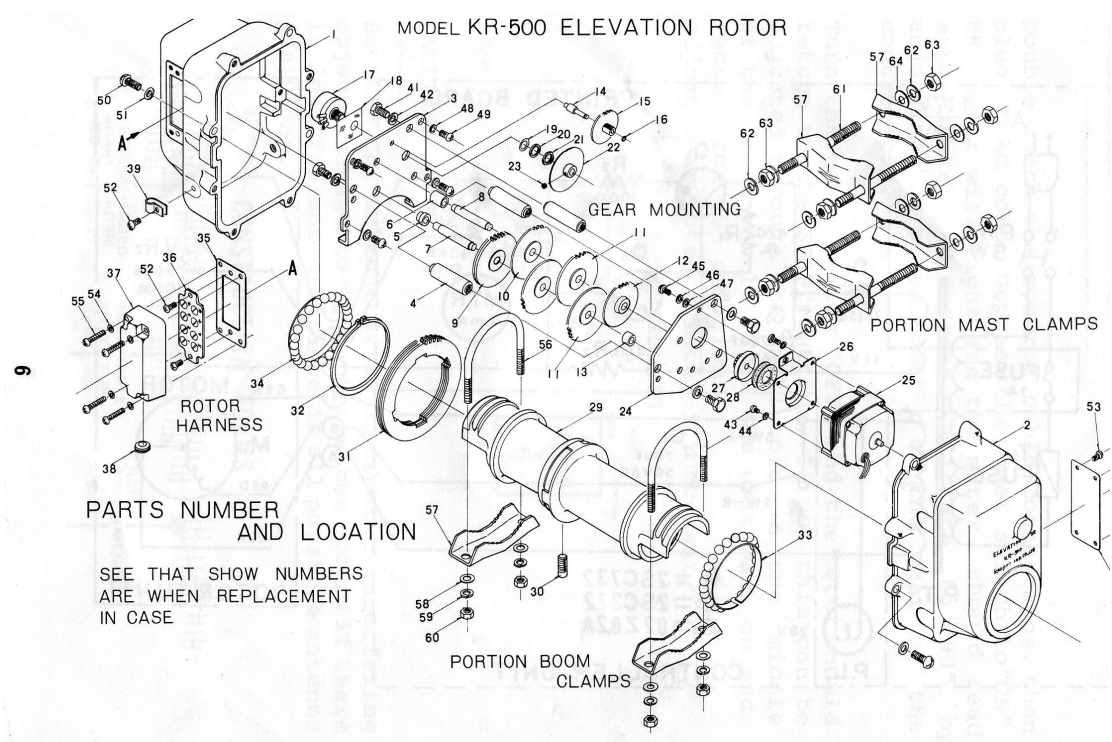

CALIBRATION/OPERATION:

Double check the control cable connections, then plug in AC cord. Depress the power switch to "ON" the meter will light and the meter should read approximately 90 degrees. Calibrate to "90" by adjusting the potentiometer on the rear of the control box.

Turn the power switch "OFF" and the meter should return to the "STOP" position, If not this can be adjusted through the small hole in the middle of the front panel. Turn the unit back on and recheck for 90° position. Adjust rear potentiometer if necessary.

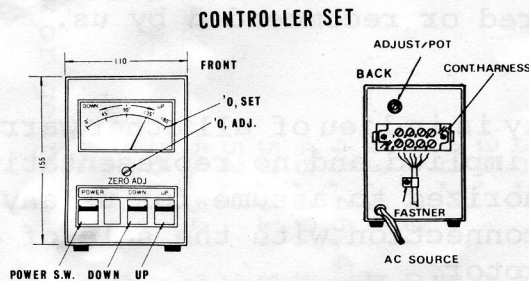

CAUTION:

Be sure the antenna array is clear of interfering objects, damage to the antenna can occur if there is insufficient clearance in all possible antenna positions.

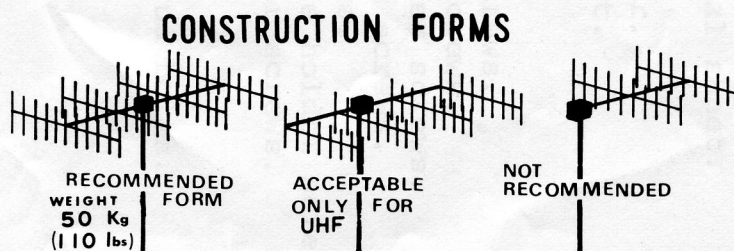

WARRANTY

This warranty does not extend if model KR-500 antenna rotor has been subjected to misuse, neglect, accident, improper wiring, improper installation or use contrary to instructions provided, nor does it extend to units which have been repaired or altered outside our service department, nor in cases where the serial number has been removed, defaced, or changed, nor to units used with accessories not manufactured or recommended by us.

This warranty is in lieu of all other warranties expressed or implied and no representative or person is authorized to assume for us any other liability in connection with the sale of our KR-500 antenna rotor.

TOYOMURA ELECTRONICS CO., LTD. reserves the right to make any improvements to its products which it may deem desirable without obligation to install such improvements in its previously manufactured products.

MAJOR PARTS LIST:

-
- | | | | |
|--------|-------------------------------|-----------|-------------------------------|
| 1.2. | Rotor housing. | 32. | "C" ring. |
| 3. | Gear mount plate. | 33,34. | Ball bearing holder. |
| 4. | Gear mount supportor. | 35. | Rubber terminal sheet. |
| 5. | Gear stud sleeve. | 36. | Terminal. |
| 6. | Stud support sleeve. | 37. | Terminal cover. |
| 7,8. | Gear shaft. | 38. | Rubber grommet. |
| 9. | Assmb gear. | 39. | Cable holder. |
| 10,11. | Internal gear. | 40. | Name plate. |
| 12. | Plastic motor gear. | 41,42. | Gear mount screws. |
| 14. | Gear pot shaft. | 43,44. | Motor mount screws. |
| 15. | Plastic pot gear. | 45,46,47. | Motor holder screws. |
| 17. | Potentiometer. | 48,49. | Housing mount screws. |
| 18. | Insulator sheet. | 50,51. | Housing screws. |
| 22. | Pot divider gear. | 52. | Terminal/cable holder screws. |
| 23. | Gear stopper screw. | 55,54. | Terminal cover screws. |
| 24. | Gear/motor mount plate. | 56. | "U" bolts. |
| 25. | AC 24 volt motor. | 57. | Clamps. |
| 26. | Motor mount plate. | 61. | Mast clamp stud bolts. |
| 27. | Disc brake/pinion motor gear. | | |
| 28. | Disc pad. | | |
| 29. | Boom shaft tube. | | |
| 30. | Stopper stud pin. | | |
| 31. | Assmb tube gear. | | |

10

MANUFACTURER.

KENPRO INDUSTRIAL CO., LTD.

TOYOMURA ELECTRONICS CO., LTD.

2-7-9, Sotokanda, Chiyoda-ku, Tokyo, Japan.

TLX 02226408 CQ TEC J

